

Safety Information

Warning!

All wiring should be installed in accordance with local, state, and national electrical code requirements under NEC/ANSI/NFPA 70. IMC threaded conduit, sealed fittings and proper electrical wiring practices should be adhered to. Improper installation can result in fire, serious bodily injury, or death.

Warning! Pay attention to the following safety practices.

- 1) Never smoke or use an open flame anywhere near the tanks or dispensers.
- 2) All mechanical joints containing fuel products must be sealed with sealant tape appropriate for the product dispensed.
- 3) Never use any tools near the dispenser or tanks that can create unexpected sparks.
- 4) Always have a fire extinguisher available in case of fire.
- 5) Always turn off all electrical power when working on any pumps or dispensers. There will always be a disconnect panel in reasonable proximity to the fuel island. Typically, this will be a circuit breaker panel. Power must be turned off before working on any electrical circuits. If you are unsure of the location, always obtain assistance to locate the disconnect panel.
- 6) It is highly recommended that someone who is capable of rendering first aid be present during the installation process.
- 7) Follow OSHA lockout/tagout procedures during installation, service, and maintenance.
- 8) Know where the emergency shutoff is located. Do not use emergency stops to disconnect electrical power. Always disconnect at the breakers.
- 9) Always cordon off all work areas from vehicle traffic.
- 10) The State of California cautions that fuel and fuel handling systems contain chemicals that are known to cause cancer or reproductive harm.

Performance Specifications

Voltage AC: 120VAC, 50 to 60 Hz	Ingress: IP67
Power (LINK): AC 28ma, DC 75ma	Max Current: 25 amp
Pulsar Input: Dry reed switch/Open Collector	Class: Class1, Division
Environmental: Indoor or outdoor use	Altitude: 2000-meter Max
Temp: -20 to +50 C (-4 to +122 F)	Relative Humidity: 97%

1. Removing the Cover *figure1*

Remove the four bolts and remove the cover.
Store the cover and bolts should they be needed for any future reason.

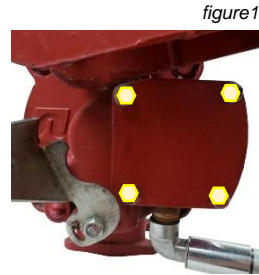

2. Wiring Connections *figure2*

The AST LINK has just three wires to connect to the pump.

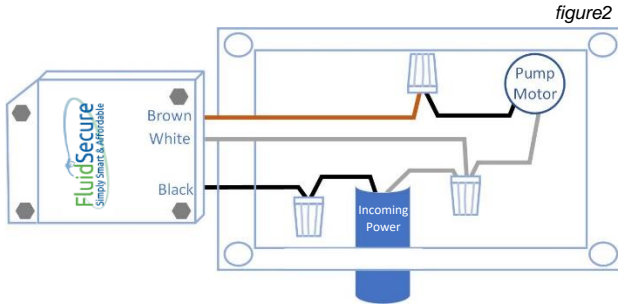

The black O-Ring must be in place before attaching the AST LINK. Failure to do so may result in death, bodily harm, and property destruction. Its purpose is to prevent ingress of a flammable product into the wiring chamber possibly resulting in an explosion.

3. Mounting the LINK *figure3*

Secure the AST LINK to the dispenser but using the four bolts provided in your kit.
The front shows the LINK and the clear operations window that shows the status of power and pulser.



4. Optical Pulsar Installation

The AST LINK is generally equipped with an optical pulser that is compatible with a 600, 700 or 900 Fill-Rite series mechanical register.

1. Remove the cover of the register and mount the Optical Pulsar. *figure4*
2. While the cover is removed, drill a hole in the bottom of the cover to allow the wires from the outer cable to be able to come through. You want to be sure the connectors are inside of the cover, not hanging freely on the outside. *figure5*
Secure the cover back onto the register
3. Connect the connectors as shown below (brown to red & white; blue to blue; green & black to black). *figure6*
4. Connect the other end of the black cable to the bottom of the AST LINK. It only goes on one way. *figure7*

The Pulsar Cable MUST be kept away from the pump to avoid vibration. When wrapped around the pump, additional pulses will be generated causing the quantity to be incorrect.



figure4



figure5

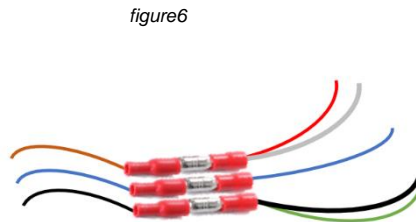

figure6



figure7